

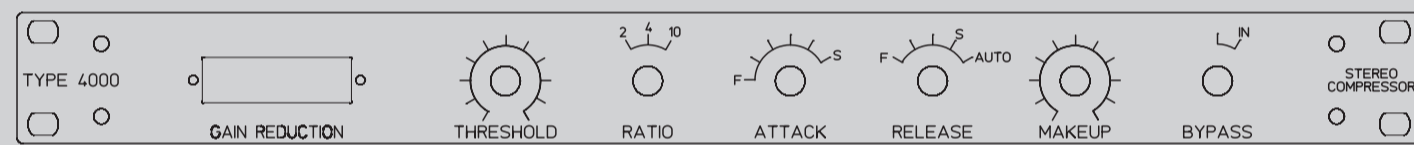

Frontpanels and Enclosures



Manual

Creating frontpanel layouts

Choosing the right method to make the layouts

Vector and Bitmaps:

There are two different methods for creating text on frontpanels.

There is the „vector“ format.

Softwares like Adobe Illustrator, Corel Draw or Affinity Designer are vector based design Softwares

And there is the „bitmap“ format.

Softwares like Adobe Photoshop is a bitmap design Softwares

We highly recommend using the vector-format for frontpanels. This gives the professional result. The edges of the text and graphics are always sharp regardless of the zoom.

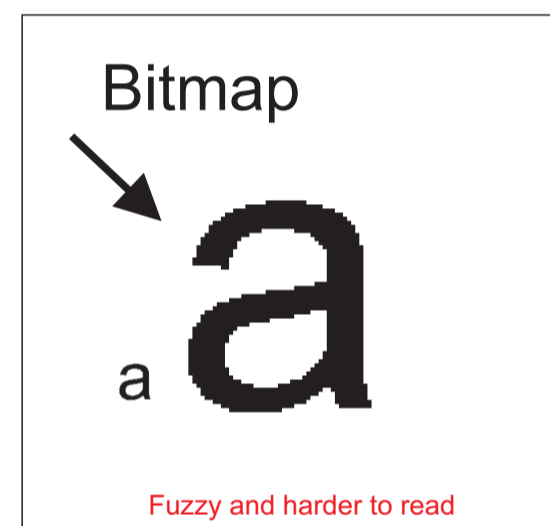
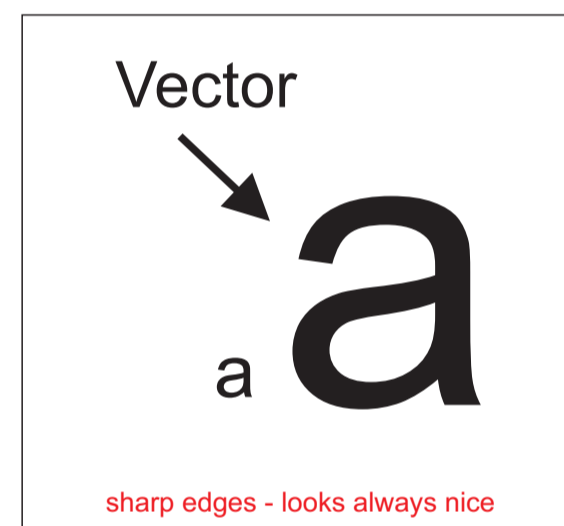

File Format

Generally we accept all file formats. But **we recommend the PDF format** for the best result.
This file looks 100% the same on every computer.
You can print bitmaps and vector files into a PDF. So please make sure you only use vector files.

Most likely the software you use already has an option to export as a *.pdf file.
If not, you can use a free „pdf printer software“, like pdf24, pdf creator, pdf forge.

1. Send the file as *.pdf to us
2. Use „A2“ (420x594mm) as the size
3. Prepare the file as shown in these examples

Examples for sending files

Bad file:

Crosshairs for every hole
Dimensioning for every object
Cuttings and text in one file
No info about material thickness, material colour, material type, print colour

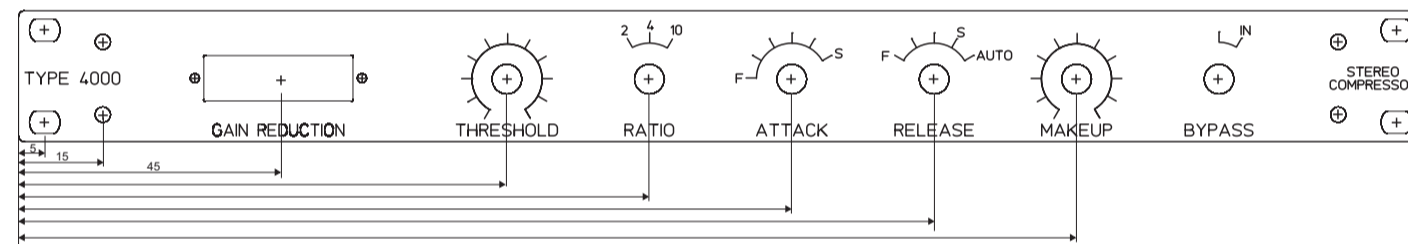

Perfect file:

No crosshairs
Dimensioning of the length only
cuttings and text separated (make sure the panel-boarder is always shown)
Info about material thickness, material colour, material type and print colour

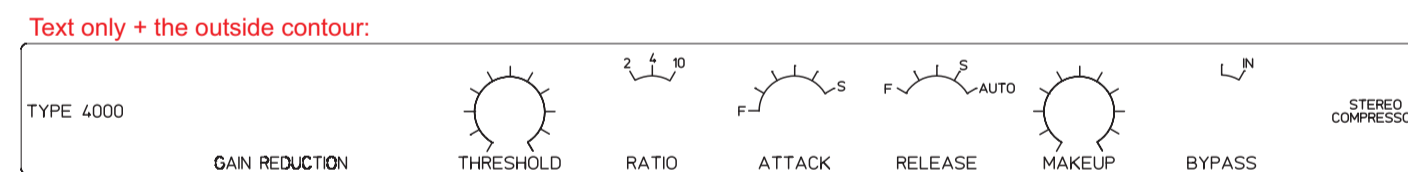
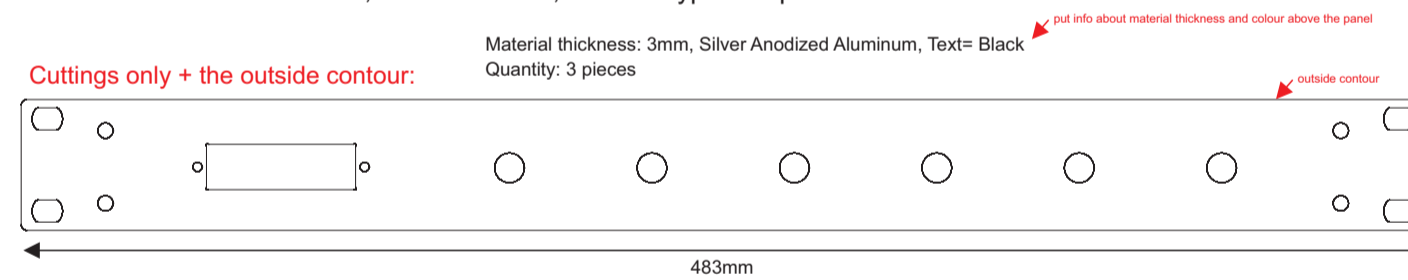

General tips for creating frontpanels

In general there is no standard for the position and size of the enclosure holes.
So every enclosure manufacturer has different positions and sizes!
Please make sure these holes will fit to the enclosure you want to use.

If you order a 1U frontpanel and our nrg-case, we'll always check if the holes will fit. If not, we will send you an mail and ask if you maybe want to use the ordered panel for another enclosure or if we should make the holes work with our nrg-case.
If you're not sure about the right holes you could also drill these 4 holes yourselfs at the end.

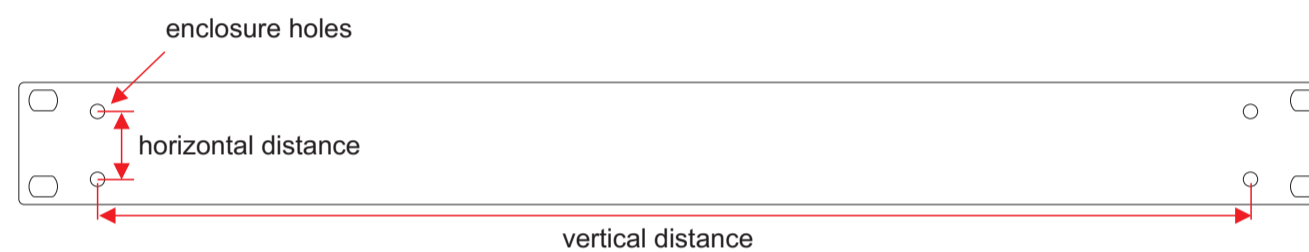

If you want us to add the enclosure holes so that the panel will fit to an enclosure from another manufacture, then just send us the horizontal and vertical distances for the holes.

We can draw your panel layout

In case you want us to draw your panel design we charge 15€ for each 15 minutes +VAT.
Most of the time a panel lasts ~30 minutes to create.
We will stop after 30 minutes if it lasts longer and inform you about it. Maybe you need more complicated scales, this can last longer.

Cutout diameters

Generally: A part with 3mm can't fit into a 3mm hole! Either the hole needs to be bigger, or the part needs to be smaller.
So if you need a hole for a 3mm LED, make this hole 3,1mm so the LED will easily fit!

The manufacturer of LEDs, switches, potentiometers always add an info about there tolerances to the datasheets of their components. If the manufacturer writes „+/- 0,1mm“ tolerance for a part with 3mm diameter. Then the part can be 2,9mm or 3,1mm. Then the 3,1mm is still a tight fit. I would recommend making a 3,2mm hole.

Potentiometer scales

Scales need to fit to the potentiometer knobs diameter.
There are also a lot of different potentiometers with different rotation angle, like 270°, 300°, 320°...
Make sure the scales will fit and make the scales a bit bigger so they will not hide under the knob.

Check your layout with a printed paper sheet

Just print the layout on paper and cut all holes with a box-cutter or scissors.

As 19" Layouts will not fit on a single A4 paper sheet you need to print two sheets and stick them together with tape. With this methode you can check this:

- Put the mechanical parts through the paper to see if it fits.
- Check if mechanical parts really fit next to each other when they're fixed into the panel
- Put potentiometer into a hole and put a knob on the pot to see if the scale is 1. not covered by the knob and 2. if the rotation angle of the scale is correct
- Check if the holes which connect the frontpanel to the enclosure are at the right position and have the right size in diameter
- Check if mechanical parts are not too close to the side panels of the enclosure (otherwise they would not fit into the case)

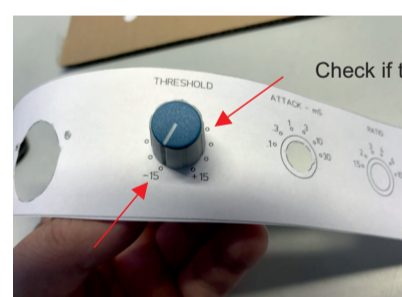
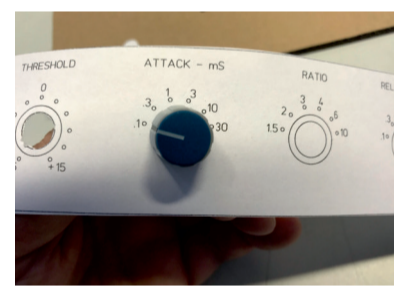
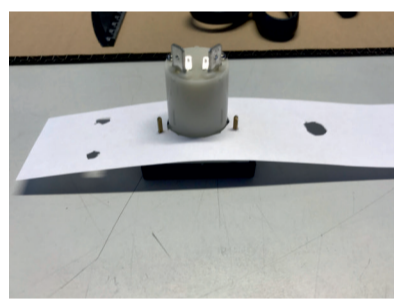
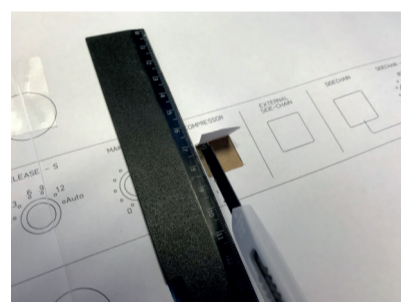
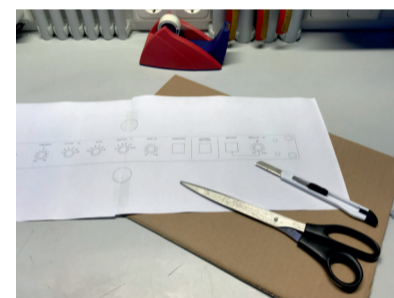
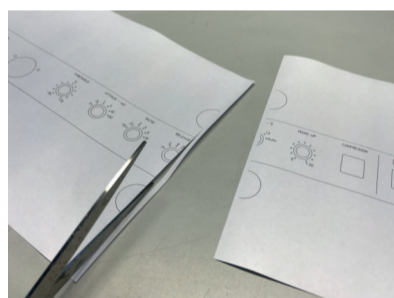
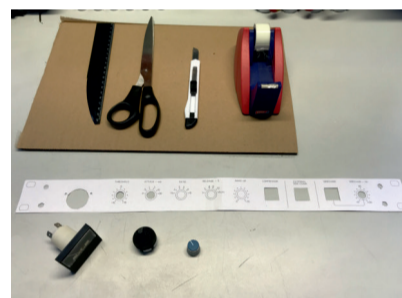

Check if the scale has the correct size so the knob will not cover the scale

Check if the scale fits to the rotation angle of the potentiometer

Make sure that elements on the frontpanel are not too close to the edge as you can't use the full 19" width. Our nrg-case has the most possible usable width (415mm width) compared to other enclosure systems.

Text is to close to the enclosure screws



Check if your printer prints the right size

Make sure you set the printer to print the „actual size“, without any up or down-scaling.

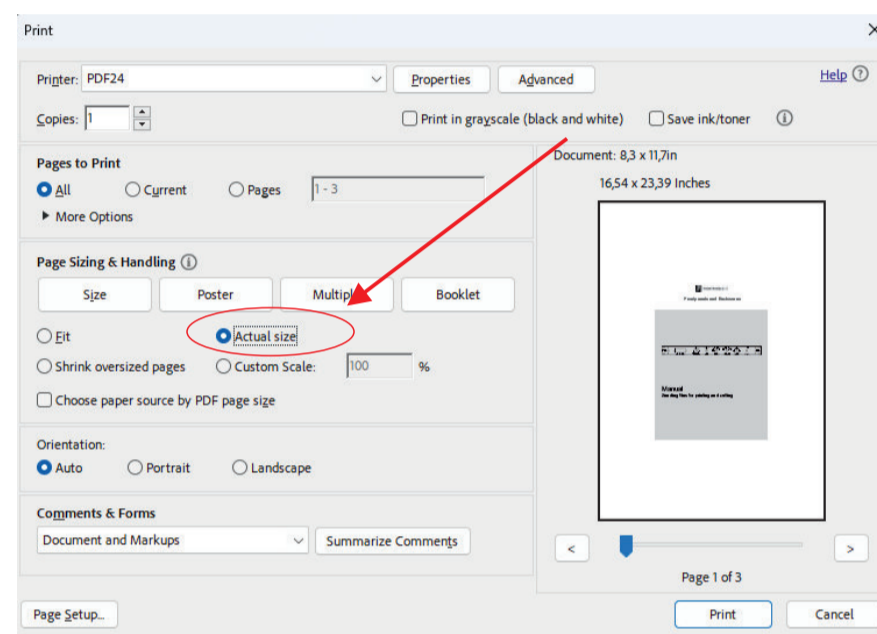

Make a test-print and check if the size is correct. Some printers change the size by some millimeters.

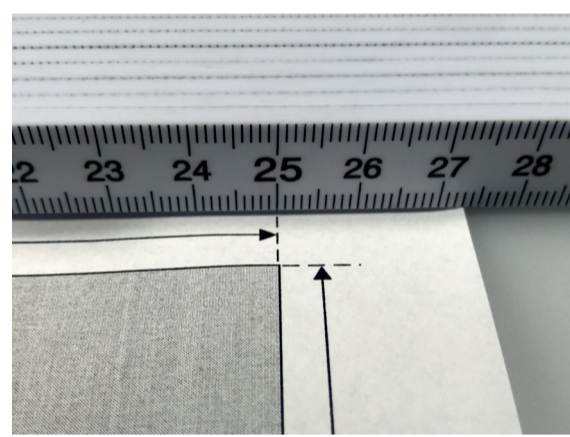
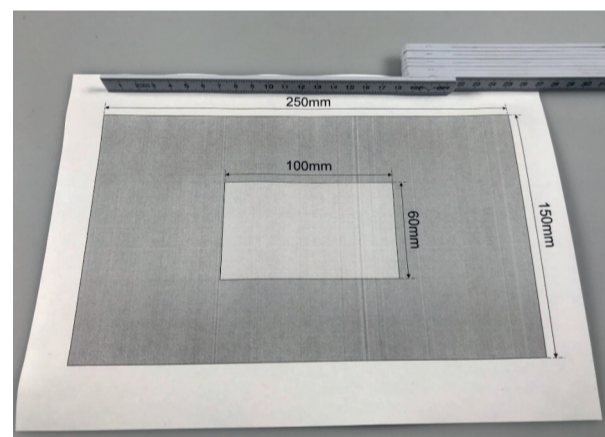

Example Frontpanel... looks good at the first glance... but it has some problems

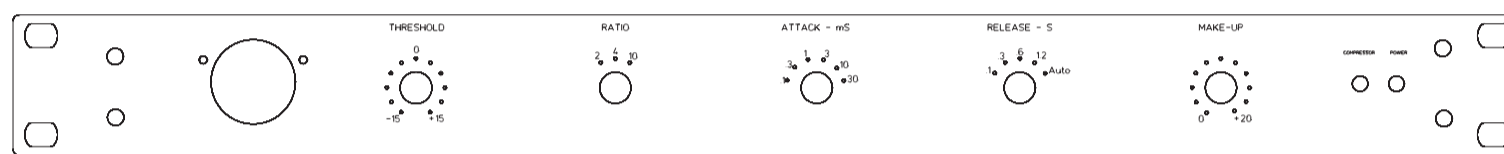

Problems explained

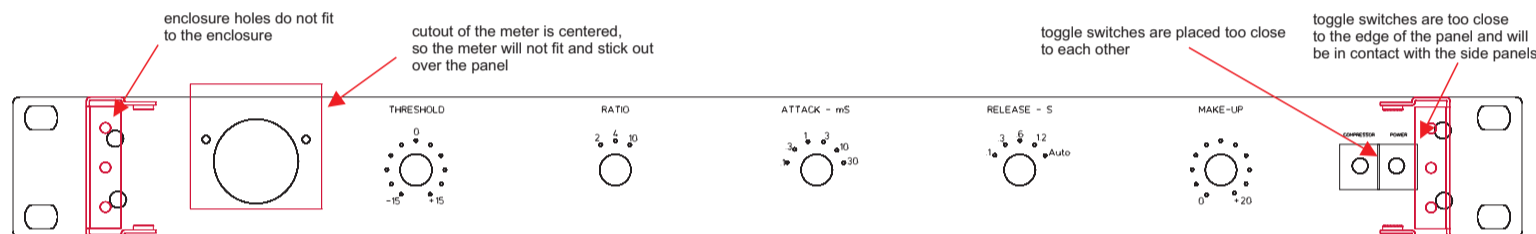

infos on XLR and IEC connectors

Many different types of XLR and IEC connectors are available and most of them need a totally different cutout. Even Neutrik has a lot of different types available. Make sure you do the right hole diameter and positions. Check the datasheets to be sure. Be careful with the Neutrik Datasheet as they display the hole-pattern mirrored. So if you would draw the cutout from the datasheet, the XLR will only fit if you would assemble the XLR at the inside of the enclosure! (wrong) The two holes to fix the xlr needs to be „top left and bottom right“.

Generally there are two common types of XLRs which are often used.

The „Neutrik D-Series“. Which are very expensive, like 5€/each xlr, and they need much space. Usually the pro audio companies like Neve, SSL, API, SPL, behringer use smaller xlr's. The benefits: They're smaller so you can put more of them next to each other. (good for patchbays or summing units), they're available with pcb pins so you don't need to use a lot of wires, they're cheaper and much easier to assemble. You just need to put the screw from the front. No need to use a nut, like with the Neutrik D-Series!

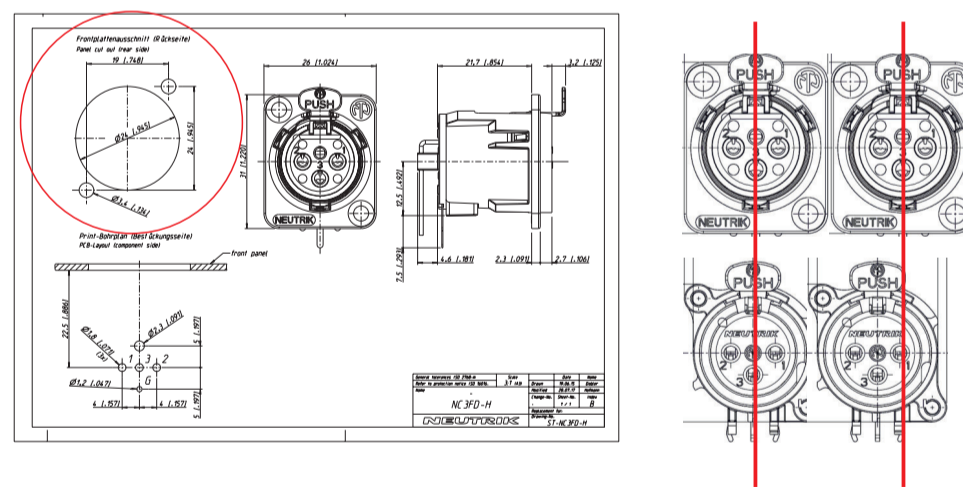

Drawing countersinks

To show that you want to have a countersink hole just draw two wo circles.

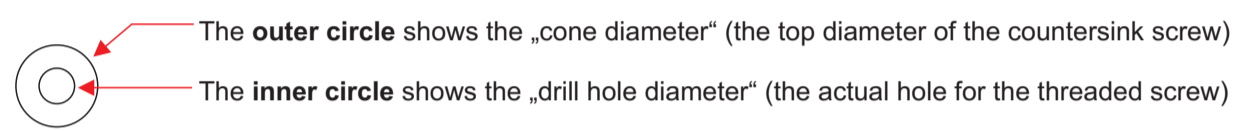

Here are some parameters for DIN 74A standard countersink screws:

Countersink	Cone diameter	Drill hole
M2	4,30mm	2,20mm
M3	6,0mm	3,20mm
M4	8,0mm	4,30mm
M5	10,0mm	5,40mm
M6	11,5mm	7,40mm

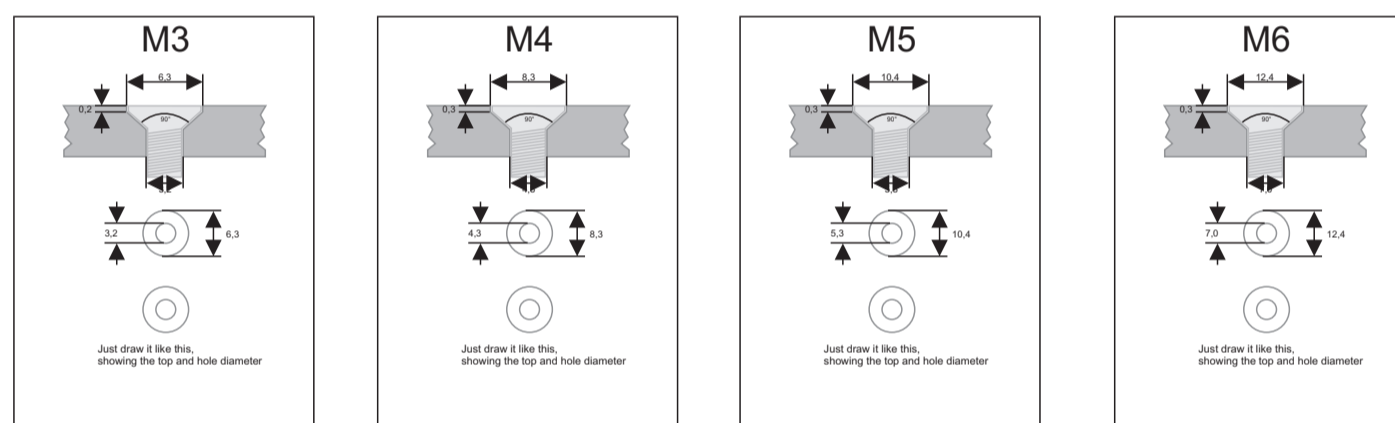

Drawing threads

To show that you want to have a countersink hole just draw two wo circles, with the outer circle not completely closed. (so we can see if it's a countersink or a thread)

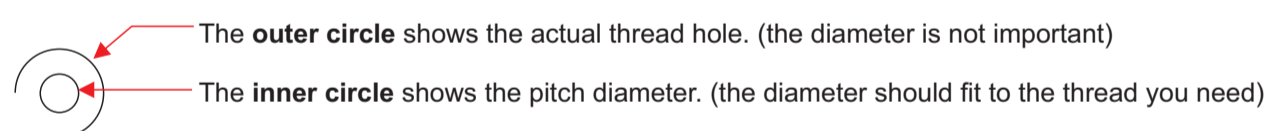

Here is a list of some standard Thread parameters:

Thread Type	Pitch diameter (inner circle)
M2	1,57mm
M3	2,46mm
M4	3,24mm
M5	4,13m
M6	4,92mm

Available colors

For **engravings**, we use infill colors, which are available in the following colors:
White, Black, Red, Green, Blue, Yellow

For **printing**, we're using UV-Printers with the CMYK color scheme, which gives technically 4 million different colors.

Pantone, HKS and RAL colors are custom or spot colors. There are websites with free online converters that can convert these color-codes, but these colors can only be approximated.
Please note that there may be differences in printing depending on the color. Colors also look different depending on the material being used.
When printing on black or dark panel- colors, we always print white color under the CMYK color to prevent the CYMK color from looking darker.

Besides CMYK (Cyan blue, **M**agenta red, **Y**ellow, **B**lack) there is „white“ as a „special color“ (spot-colour).
When sending white text to the printer, no printer will actually print white. So we need to convert your white color to the „spot-colour“ (called „RDG_White“).
If you have a layout for a black anodized frontpanel you can use black color on white background and put the info on top of the drawing, like „black anodized aluminum, or RAL color 5009, printing=white color. As shown here:

Material thickness: 3mm, Black Anodized Aluminum, Text= White
Quantity: 3 pieces

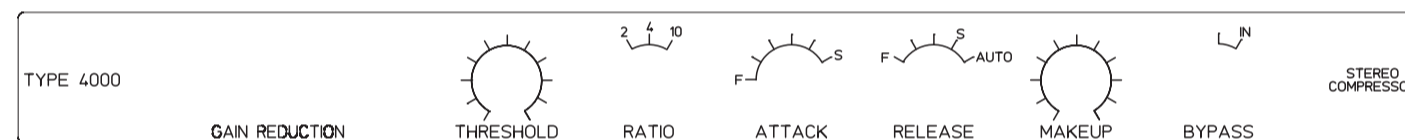

Full surface graphics

When printing textures or backgrounds that fill the entire front panel, print the background slightly larger to prevent clipping of the background image at the edges.

